

just sheds inc.

www.just-sheds.com



HOW TO BUILD SHEDS

CONSTRUCTION GUIDE

| SEC. | CONTENTS | PAGE |
|------|-----------------|------|
| | INTRODUCTION | 2 |
| 1 | START UP | 2 |
| 2 | EXCAVATION | 3 |
| 3 | FOUNDATION | 5 |
| 4 | FLOOR FRAMING | 11 |
| 5 | WALL FRAMING | 14 |
| 6 | ROOF FRAMING | 18 |
| 7 | ROOFING | 22 |
| 8 | WINDOWS & DOORS | 22 |
| 9 | SIDING | 23 |
| 10 | GLOSSARY | 25 |
| | CONCLUSION | 30 |

JUNE 2005 ISSUE

Discover what we will help you build.

FREE & EASY

THE YES YOU CAN BOOK
FOR ALL OF OUR
DO-IT-YOURSELF
SHED PLANS



*Over 120 shed plans
to choose from*

Copyright ©
2005 Just Sheds Inc.
All rights reserved

INTRODUCTION

Here we freely provide, for the do-it-yourself shed builder, additional helpful construction tips on building sheds that are designed by Just Sheds Inc. This guide can be used for all of our plans. It is divided into sections and sub sections for easy reference.

When considering such a fun, money saving project please read it through entirely and then you will discover what we can help you build. Just imagine how rewarding that will be.

The printable version of our Construction Guide in PDF format is free to everyone to print. It requires [Adobe Acrobat Reader](#), which is also available free on the home page of our web site.

Our guide will also be of interest to anyone else who is interested in such a building project although it is not written, illustrated nor intended for use with shed plans designed by others.

More information, illustrations and *italicized* words can be found in our Glossary.

It should be noted that unless stated otherwise plan # 1312 is the plan used throughout this guide so as not to confuse the reader. It is the shed illustrated with a blue door shown on the guide's top right cover. It is illustrated as built on a *concrete pad* instead of on a wooden floor. The door is in the front wall which is 8' - 0" wide from left to right (plus the thickness of the siding). It is 10' - 0" deep from front to back (plus the thickness of the siding). All of these dimensions exclude the thickness of siding because there are many styles of siding that you can choose from and it has no bearing on the construction of your shed at the *framing* stage.

1 START-UP

1-1 Service Lines

1-2 Permits

1-3 Our Three Types of Foundations

1-4 Skid Foundation

1-5 Concrete Pad Foundation

1-6 Pier Foundation

1-7 Foundation Photos

1-1 Service Lines Once you have your plans and know where to place your new shed you should contact your local public utilities if you are going to dig deep. They will inform you about any pipes or cables that are buried in the ground in the area. This is usually free of charge. You should also avoid disrupting any part of your septic system.

1-2 Permits Know where your property lines are and then contact your local building department and inquire about the required distance needed for side and rear yard setbacks if any.

Also inquire about any building permits that you may require. Smaller sheds in many areas however do not require a permit.

1-3 Our Three Types of Foundations Some of our different shed plans offer three types of foundations that are suited to small or very large size sheds. Some of our plans have all three in one set of plans.

1-4 Skid Foundation The first and easiest type to build is where the floor *joists* are nailed to a skid foundation, which rests on a small gravel bed. This type of construction is well suited for small to medium size sheds used for storing such things as garden tractors, motorcycles, lawnmowers etc. Or maybe just used to make more room in your basement or garage.

1-5 Concrete Pad Foundation The second type is built on a *concrete pad (slab on grade)* onto which the walls and the roof are built. This type of construction is well suited for our very large sheds where heavy loads such as bigger garden tractors or even animals may be kept. All of our shed plans can be built in this very strong, long lasting and economical way.

1-6 Pier Foundation The third type is better suited to sloping yards or soils that are subject to movement. The concrete *pier* style that supports an elevated wooden floor with the walls and roof placed on top. This style can support medium loads and store almost anything you need storage for.

1-7 Foundation Photos You can see some of our customer's pictures of different foundations in our on-line Photo Gallery.

2 EXCAVATION

2-1 Chose a Location

2-2 Benchmarks

2-3 Mark the Four Outside Corners

2-4 Batter Boards

2-5 Excavating for Piers

2-1 Chose a Location Once you have chosen a location for your new shed and you chose to build your shed on a skid foundation remove the topsoil in the area down to the depth mentioned in your plans. In the case of plan # 1312 the area will be just one and half feet wide by ten feet long for each of the two skids. If you have chosen to build your shed on a concrete pad, dig out an area that is at least 6" bigger than the shed is all the way around. This allows for working space and formwork. Dig it out in a shape that allows the *concrete pad* to be thicker under the walls and reinforced when specifically called for in the plans. If you want, some of this excavated material can be replaced with any granular material that is compactable and inexpensive to buy. This should be done before you build the formwork as described in **sec. 3-7** There may be materials in you area that need no compaction at all. The amount needed will of course depend on your excavation and on the elevation you want for your shed floor.

Also remember that the finer the materials are the easier they are to shovel and handle. When your excavation is finished it should look like the areas and items in **illustration # 2** on page 9.

2-2 Benchmarks If you choose to build your shed on concrete *piers* you should find or build a good benchmark. Benchmarks are just reference points (**see illustration # 1 and 2**) used to find and establish

the elevations of the different parts of your shed. For example, it is necessary that the 4 foundation footings have the same elevation when the concrete is poured in them. On top of these are placed the concrete blocks etc. and then the wooden floor *joists*. The end result of this should be a *level* floor. It is your benchmark that will help and guide you in this task.

It can be almost anything; a specific point or mark on a building or sidewalk, as long as it stays put and is clearly marked so that you always use the same point. You can even use the top of a 2" X 4" wooden stake hammered very firmly into the ground. A 2X4 stake was the chosen benchmark for this shed building project. **See illustration # 1 and 2.**

2-3 Mark the Four Outside Corners After completing the work described in sec. 2-2 you should mark the 4 outside corners of the shed with small stakes. Make sure that the corners are at 90° angles. Measuring the distance from front left to the right back corners and comparing this with the distance between the remaining corners will confirm 90° angles when the distance is the same. Make the necessary adjustments so that the two are exactly the same and the area still is 8' X 10' or whatever the size of your new shed is going to be.

2-4 Batter Boards Erect the 8 batter boards and put up the string lines as shown in **illustration # 1**. They can be built out of any sturdy lumber strong enough so that they stay put if bumped into and support the tightly tied string lines tied onto them. They should be installed about 3ft. from the shed's location. A few feet more if you need to dig deeper than 3 feet. As these strings are only strung when needed it is a good idea to make a small saw cut in the top board marking the right location for it when next needed. The batter boards are removed once the foundation is complete and ready for the wood *framing*. Batter boards are not used if you choose to build your shed on a skid foundation or a concrete pad.

ILLUSTRATION # 1

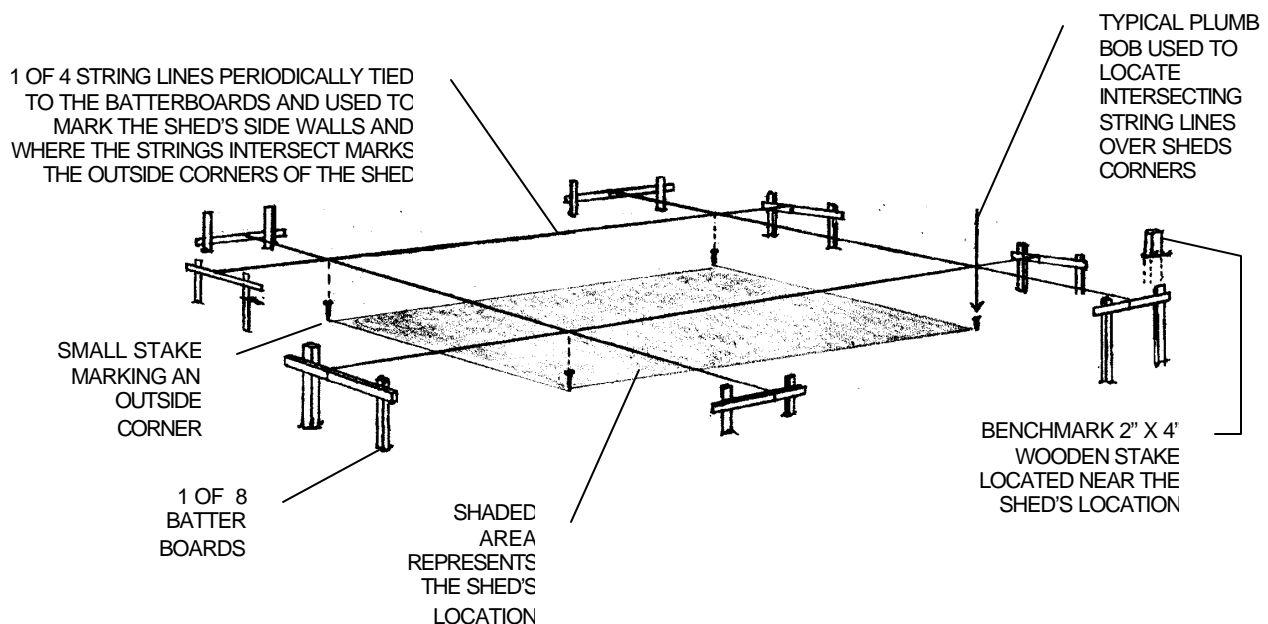

2-5 Excavating for Piers If you have chosen to build your shed on *piers*, dig the four holes so that they can accommodate the foundation footings as called for in your plans. You can reinstall the string lines on the batter boards anytime you wish to check on your progress. The footings do not need to be in the exact place as the concrete blocks can be somewhat off center on the footings as long as the blocks are plumb (straight up and down) and at exactly 90° angles to the other concrete block *piers*.

3 FOUNDATION

3-1 Uniform Elevation

3-2 Keeping it Level

3-3 Building Piers

3-4 Building Piers of Different Heights

3-5 Pouring Concrete for Piers

3-6 Building on a Skid Foundation

3-7 Concrete Pad Forming

3-8 Concrete Pad Finishing

3-9 When the Concrete has Hardened

3-10 Concrete Blocks

3-11 Backfilling

3-1 Uniform Elevation Use a carpenter's *level* and a straight edge (a long and very straight 2X4 will do nicely) to help you establish a uniform elevation for the footings from the benchmark that is shown in **illustration # 3**. If poor soil conditions or the slope of your site do not allow you to build it this way you can step down the footings in multiples of 8". The technique for doing this is shown in **illustration # 2**. It is best to use multiples of 8" because that is the height of each standard concrete block with its mortar and so you just use blocks in different amounts according to your needs. If you plan to complete the foundation by pouring a concrete *pier*, which is another option, then the elevation at the bottom can be different but the tops of the *piers* must always be at the same elevation. This is important because all of the roof *rafters* described in exact size, cut and angles in the " RAFTER CUTTING LAYOUT " page of our plans have actually been cut and proven to fit. In order for the *rafters* to fit properly as planned and described, it is important that the corners of your shed have 90° angles and the floor be *level*. *Level* within ¼ of an inch from the lowest point on the floor to highest is good.

3-2 Keeping it Level This "*level*" standard is actually not that difficult to achieve, because you can use your benchmark to check on and make adjustments as you progress. Once you have completed your excavation, hammer a small *grade* stake in each of the four holes. Put them in an area near the outside of the footing as described in illustration # 2, *pier* B. This small *grade* stake is needed if you decide to pour the concrete right into the four holes without building concrete forms. Just pour to the top of the stake and *level* off with a trowel or just use a block of wood. It does not need to be smooth. It is easier to build this way but the holes must have a size similar to the required footings as stated on the plans. If you need or are going to build with concrete footing forms because of soil or other conditions then you can use the forms as an elevation guide instead of the four *grade* stakes. Examine the poured concrete for *levelness* when it has cured. Further minor adjustments needed can be made with the thickness of the mortar, but do not make a mortar line thicker than ½.

3-3 Building Piers Build one *pier* first and then measure over to the other ones and build them one at a time. You can make minor adjustments as you go. Making and keeping the corners square (90° angles) is also important and not really hard to do. You should confirm this as you go, by using the methods described in sec.2-3 the two cross-distances mentioned should be within ¼' of each other.

3-4 Building Piers of Different Heights The top of the benchmark shown in **illustrations # 1 and 2** always represents the chosen finished floor *level* (the elevation you want your floor to be at). The bottom of your straight edge is also at this same *level* plane and so you just measure down to get at the needed elevations in the different *piers* in multiple increments of 8". The straight edge must of course always be *level* as shown. In **illustration # 2**, *pier C* shows a small concrete footing in a shallow excavation with 2 blocks on top, which meets the needs here, all hypothetically of course. *Pier D* shows the footing's concrete was poured in a wooden form and it has 3 blocks on top. The tops of *piers C* and *D* are at the same *level* but the bottom of *D* is 8" lower for whatever reason. *Pier B* hypothetically had its concrete for the footing poured right into the excavation that was dug. A *grade* stake was used here instead of forms to establish at what *level* the concrete should be. On top was placed 6 blocks; the bottom of this *pier* is much lower than the others because of a hypothetical back yard slope. The 6 blocks times 8" each equals 48". This leaves 8" left from 56" that is stated in the illustration. The 8" left represent the space needed for the wooden floor which for this particular shed plan calls for 2" X 8" floor *joists*, which is actually closer to 7 3/8" high plus 5/8" for the *plywood* equals 8". You can see from all this that making the needed calculations and establishing the different elevations is actually quite easy to do. It certainly is much easier than digging the *piers* needlessly deeper, it gets you a better shed and it saves you money.

3-5 Pouring Concrete for Piers Once you have the 4 holes dug out and/or formed with wooden forms and stakes you can pour in the needed concrete. The type of concrete mix bought in a bag requiring only water to be mixed with it is a good product for this job. After it has hardened as described in sec. 3-9, you can proceed with the work described in sec. 3-10.

3-6 Building on a Skid Foundation Building on a skid foundation or a *concrete pad* is different in that among other things there are no batter boards used. You make it *level* and square as you build. For a skid foundation (see **illustrations # 3** on page 8) lay the skids on the required *level* gravel. Nail all the *joists* in place as described in the plans and then just move one skid back or forth a bit so that it is square as described in sec.2-3. Install the *plywood* as describe in sec. 4-6 to keep it square.

3-7 Concrete Pad Forming For the *concrete pad* version, after you have completed the excavation as described, proceed to build the concrete form with 2" X 10" lumber that is preferably as long as each side of the shed. Actually it is preferable that 2 of the 4 boards should be 3" longer so that you can nail them together for strength. It should be remembered that concrete is very heavy (about 4000 lbs per cubic yard) and your forms must not bend or bow out because some of the finished concrete can be seen.

At this stage you are basically building a box in the sheds desired location. Lay it out so that it is near to being square (a few inches within being square) as described in sec. 2-3. Nail the 4 boards firmly together so that you have a form that will make an 8' X 10' concrete pad. Find the highest point in your excavation using a carpenter's *level* on the top edge of the so-called box and start building and securing your concrete forms here. At the highest point of the box, nearing the highest end of that board, drive the first stake firmly into the ground and then secure it to the board.

ILLUSTRATION # 2

Illustrated below is our shed plan # 1312 superimposed on concrete piers. It is well suited to smaller and medium size sheds, or sheds that will not have very heavy loads placed on the floors. This type of construction is well suited to any kind of soil that is not stable and in yards that are not level.

All of the shed plans that are shown on our web sites that have a "P" after their plan number can be built this way.

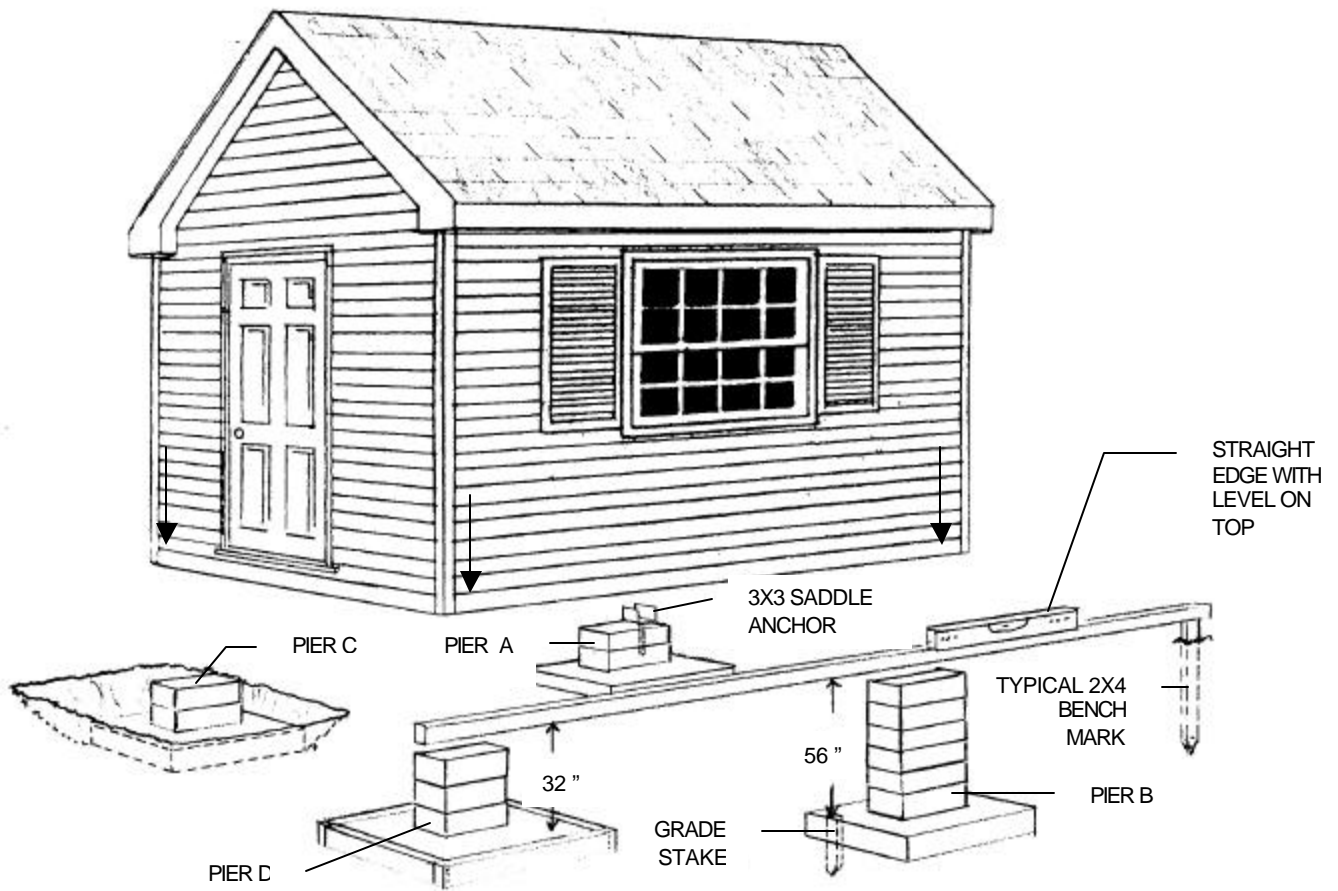

Discovering what we will help you build.

ILLUSTRATION # 3

Illustrated below is our shed plan # 1312 superimposed on a skid foundation. It is the easiest type of foundation to build. The floor joists are nailed to 6"X 6" wooden skids, which rest on a small gravel bed.

This type of construction is best suited to stable soil.

All of the shed plans that are shown on our web sites that have an "S" after their plan number can be built this way.

THE PLYWOOD IS NOT SHOWN ON THE FLOOR JOISTS HERE TO AID IN THE ILLUSTRATION. FOR MORE INFORMATION ON INSTALLING THE PLYWOOD SEE ILLUSTRATION # 5

For more illustrated details on building this shed above the foundation stage see illustrations 5,6,7,8 and 11.

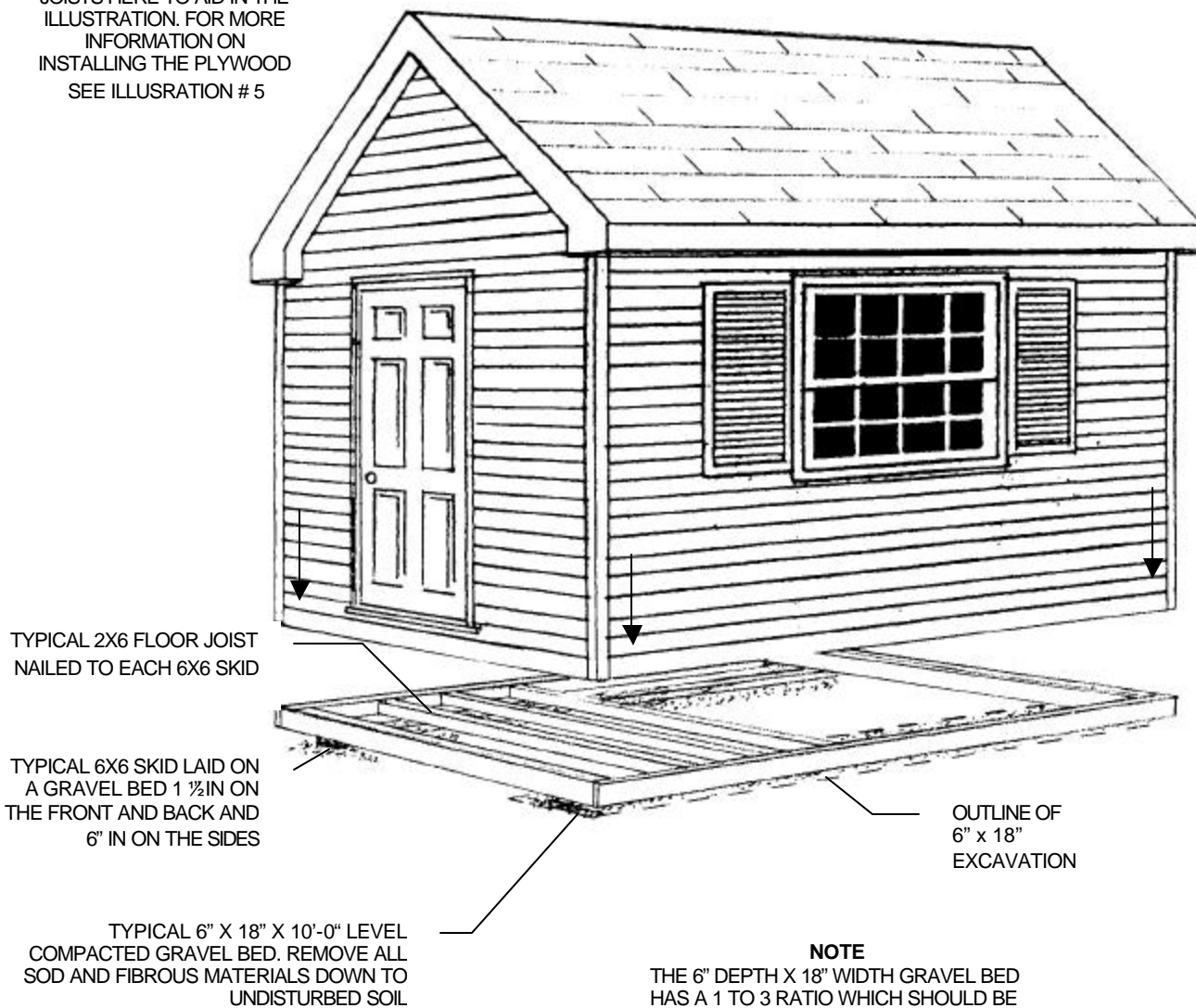

NOTE

THE 6" DEPTH X 18" WIDTH GRAVEL BED
HAS A 1 TO 3 RATIO WHICH SHOULD BE
MAINTAINED IF DIGGING DEEPER

THERE MAY BE GRAVEL OR GRANULAR
MATERIAL IN YOUR AREA THAT DOES NOT
REQUIRE COMPACTION

ILLUSTRATION # 4

Illustrated below is our shed plan # 1312 superimposed on a concrete pad. It is well suited to very small and/or very large sheds, or sheds that will have heavy loads placed on the floor. This type of construction is well suited to almost any kind of soil in yards that are fairly level.

All of the shed plans that are shown on our web sites that have a "C" after their plan number can be built this way.

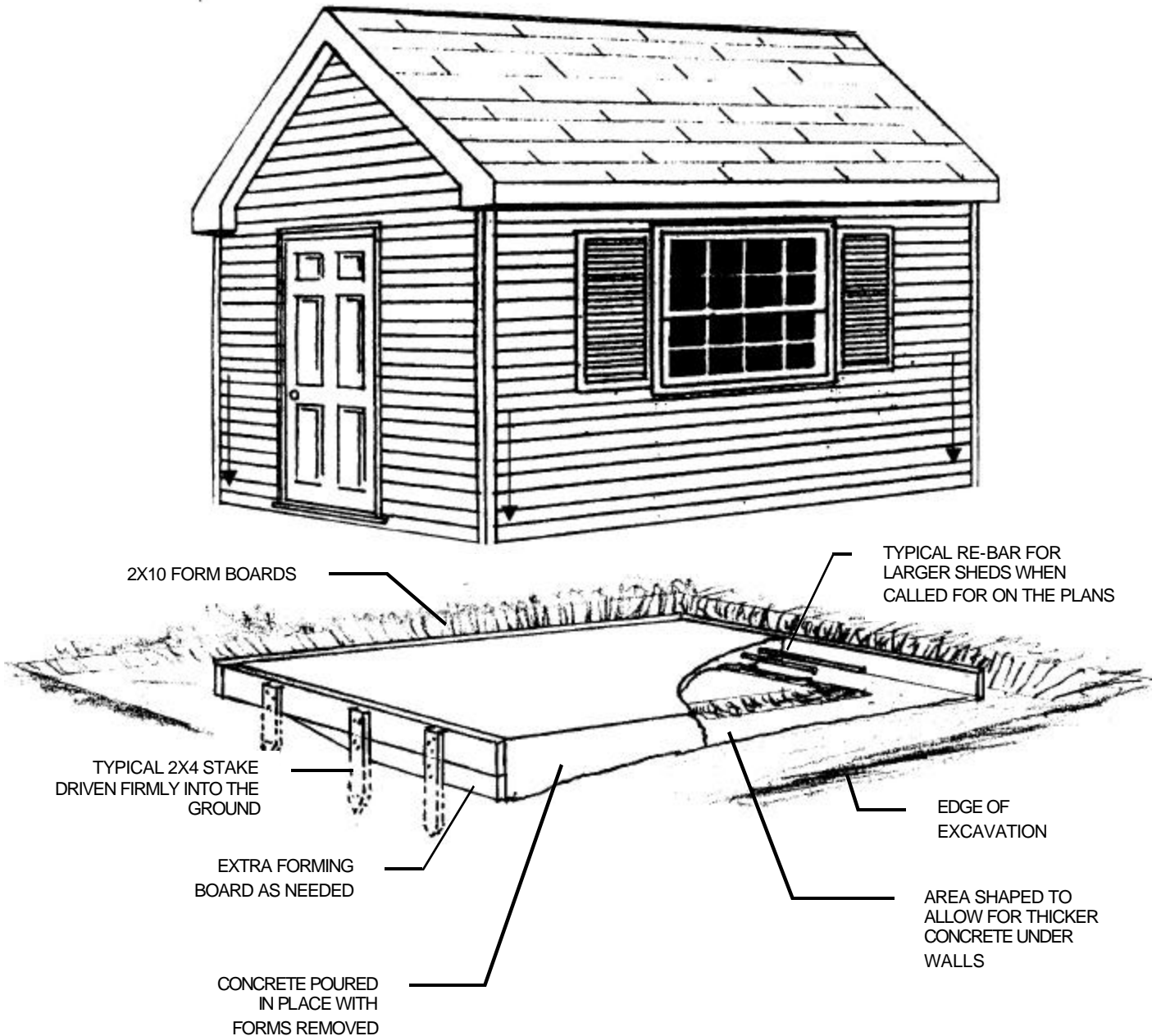

Install the second stake near the lowest point of that board; while remembering you should have a stake every 3 feet. You may notice at this time there may be a small space under the form. A space of $\frac{3}{4}$ is ok in that concrete should not be so watery that it escapes through it. Larger spaces can be blocked with an extra forming board as described in **illustration # 4** on page 9. Proceed in this same manner on the next part of the form after you have made it completely square as described. Digging under the forms a bit and then hammering the stakes down further can make minor adjustments in *level*. The top of the form and the concrete poured into the top of the form should meet the *level* standards set in sec. 3-1.

Once the formwork is complete you can install the concrete's steel reinforcing if and when it is called for in the plans and specifications. Steel re-bar should be about 2" below the surface and can be held there by placing it on top of pieces of concrete or something like old bricks something that will not rot or you can buy what the industry calls chairs, which are designed for this purpose, but you may have to buy a hole case full. Wire mesh which is often buyable in part rolls or in 4X8 sheets is often simply laid in the form and then with a rake it is pulled up to the mid point of the concrete as it is being poured into place. Do not use concrete that is weaker than called for in the plans for your new shed.

3-8 Concrete Pad Finishing Once the concrete is poured in place you should install the *anchor bolts* as called for in the plans and specifications. Do not wait until the concrete starts to set. Unless indicated otherwise they are installed 2" in from the concrete's edge and should be placed in an area not near wall *studs*. Check your plans. Once the concrete firms up it is trowelled smooth. You may have to do this a few times to get the desired results. If this is your first experience with pouring and finishing concrete do not leave the site. Concrete can set surprisingly fast and you only get one chance to finish it. When this is done it's best to protect it from rain and direct sun with a tarp if you have.

3-9 When the Concrete has Hardened After the concrete has hardened which can vary from 1 to 2 days or even up to 7 (it depends mostly on warmth and dryness) you can lay the concrete blocks or start the wood *framing* depending on the building method chosen for your new shed.

3-10 Concrete Blocks You should only use the kind of blocks that have square edges and flat smooth sides and ends as shown in all our plans. The standard style of stretcher blocks does not look suitable and frost can hold and lift them thereby changing the elevations you worked hard to obtain. The type of mortar mix you just add water to is a great product for this job but it should be mixed very well because the more you mix it the better it sticks to your trowel which is very handy for people who are new to this. Last but not least you should install the saddle anchors, making sure that they are installed in the right direction and alignment.

3-11 Backfilling When all the mortar and concrete is dry you can remove the batter boards, concrete forms and benchmark. Backfilling around the concrete block *piers* should be done with care and equally on each side so as not to push it out of plump. The *concrete pad* on the other hand will in all likelihood never move.

Got questions?

Just use the customer service buttons found throughout our websites



4 FLOOR FRAMING

4-1 Framing Techniques

4-2 Platform Framing

4-3 Using Crooked Lumber

4-4 The Nature of Wood

4-5 Built up Beams

4-6 Tongues and Groove Plywood

4-1 Framing Techniques Our entire portfolio of shed plans use only standard “Platform” *framing* techniques and materials. This is the most common method of building homes and small buildings in North America and is rapidly being copied in many parts of the world. It’s also the best way to build sheds because it has the advantage of cost saving, adaptability and strength. It is also an easier way to build and gives a lot of pride and self-satisfaction, especially when compared to older methods of building with wood in the past, such as balloon *framing* or post-and-beam construction. Post-and-beam construction is the method seen in old pictures of barn rising where a dozen or so men are seen working in the roof *rafters*, which is clearly not an easy task.

4-2 Platform Framing This guide will go into more details as we go but for now you can see from the following brief descriptions that platform *framing* is much easier. Unless you are building on a *concrete pad* (in which case it is your platform) you would first install the skids or main beams as the case may be and then floor joists and *plywood*. This, once completed gives you a nice working platform on which you build the next parts (hence the name platform *framing*), which are the walls. All the walls are built laying down flat on the platform and then they are put aside (if you still need the platform to build more walls) or they are put upright and installed in place (all of which depends on which walls you chose to build and install first). Once all the walls are built and installed and then the next floor would be built in the same way just described. It is the part of building that goes up fast and gives the most self-satisfaction.

If it does not have a second floor you would build the roof. For many of our larger sheds you would start by installing the ceiling *joist* first. Onto this you temporarily put the roofing *plywood* and this then becomes your next platform from which you would install the roof *rafters*. All of this work must of course be done with the highest regard for safety.

4-3 Using Crooked Lumber The materials list for the wooden flooring part of this actual shed calls for 3 pieces of 2”X 8”X 16’ which are then cut in two for each of the two 3-piece built up beams shown in **illustrations # 7** on page 14. All the lumber specified in our materials list is always based on it being delivered to you and in sizes commonly stocked. You may however if available choose to buy shorter sizes and pick it up yourself.

While the novice builder may logically only want straight lumber for his or her new storage or garden shed, (more than one quarter of our shed plans are actually bought by women) it is, in fact, more important to select which pieces you use first, where you use them and in which way. This is important to know because lumber does not stay straight nor does it stay crooked, it changes with its moisture content. Wood when it is cut and kiln dried in a lumber mill is usually straight because it has the same moisture content.

The most common way to deal with crooked lumber is to always put the crown or bow up. No matter what you are building the crown or bow is always up. The weight on the floor or roof will push it down somewhat. Just imagine what you would have if they went down or even worse some up and some down. The bow is always up and the bowed members should be beside each other not one here and there. Lumber that is badly bowed is used for bracing, stakes or simply cut into shorter or smaller pieces where it is not noticed.

4-4 The Nature of Wood The construction industry defines moisture content in wood by percentage in weight. Generally the Home Building Industry uses only kiln-dried wood or wood that does not have moisture content greater than 17%.

This moisture percentage can have a big effect on wood as it can expand the wood by as much as 10% in width. It can also change greatly with rain or even moisture in the air. This is important to remember as all the measurements in our plans for lumber cutting are based on this. This can at times make a big difference when for example the 2X4 *lintel* shown in **illustration #8** on page 15 is not as wide (or tall on it's edge) as it should be then the *cripple stud* that goes on top of it can be too long or too short. Moisture content does not cause wood to expand in length to any extent.

Moisture content also has an effect on the way wood cups and twists as the sap wood and heart wood are not uniform and even throughout a typical board when cut out of a log as shown in **illustration # 5** The cupping is caused because sap wood and heart wood absorb moisture differently and twisting is caused because the grain is not uniform throughout the log. This is one of the many reasons why carpenters always check all measurements (regardless of source) and of course they report any mistakes. This is a very standard practice in the construction industry.

Some lumber in our plans requires that measurements be taken before cutting or notching this is do to the nature of wood and the size of the buildings.

ILLUSTRATION # 5

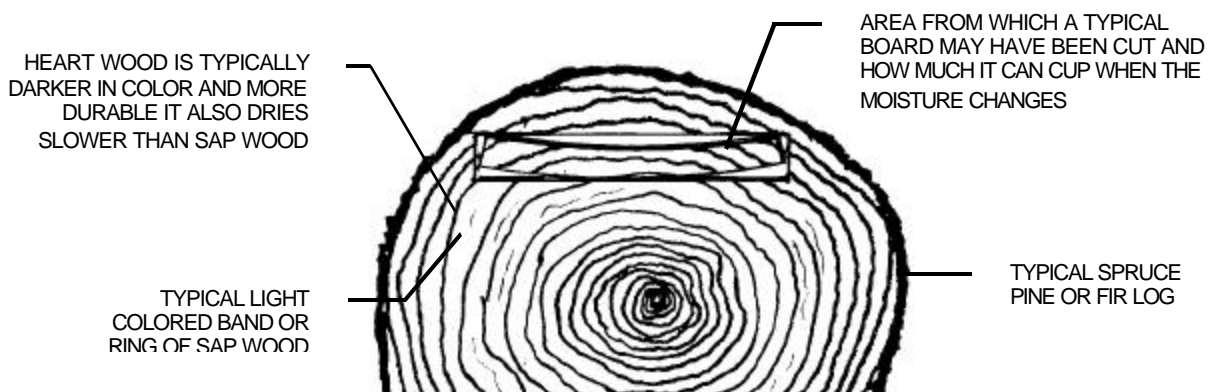

4-5 Built up Beams Start the actual floor *framing* as shown in **illustration # 7** on page 14 by selecting the straightest 2X8 then install it as the first innermost piece of the 3 piece built up beams that will support your shed. Nail it to the saddle anchor.

Then install the double *joist* under the outside walls. Notice they do not have *joist* hangers but rest on top of the concrete block and are nailed into the end of the 3 piece built up beam. Use the straightest *joist* you have for this part. Next come the middle *joist* hangers and *joists* as called for on your actual plans.

Care must be used when calculating, measuring and cutting all *framing* members so that when put together they fit well. Next install the two remaining pieces of the built up beams and nail them together as called for on the specifications that came with your plans. The double floor *joists* under the outside walls must also be nailed together like the beams but it is easier to nail them together when this part of the *framing* is rigid enough to take heavy hammer blows. Many experienced carpenters will use 3 1/4" spiral nails for this but drive them in at a bit of an angle so they do not come out the other side and become a safety hazard.

These nails can be used to nail all the *framing* members and so you need buy only one size and one size fits all. Next install the *bridging* as described in **illustration # 7** on page 14 if and when they are called for on your plans. In a similar way you should also install any *backing* that is needed under any of the second floor's flooring *plywood* so that the sheet's edges are supported within an inch or two of any sheets edge.

All the edges of all sheeting must be supported (within 2 inches of each edge) with solid wood *backing* *H clips* or tongue and groove *plywood*. This is most important on sheeting that support any weight.

4-6 Tongue and Groove Plywood Once the structural flooring members are in place you can install the *tongue and groove plywood* starting at the edge of the *framing*. Please note that a 4X8 sheet of *tongue and groove plywood* actually only covers an area that is 47 1/2" wide. So if by way of example your shed needs 3 sheets to cover 12' you would be short 1 1/2". In this case you would start the *plywood* in 3/4" and leave a 3/4" space at the other end. This saves time and money and works well as long as all the sheet's edges are supported and that's the nice part about *tongue and groove*. The tongue of one sheet is supported by the groove of the other. To get the *tongue and groove* to fit together can be tricky when either one is damaged or all the *joists* are not installed with all of the crowns up. Start by checking for damage. Any damaged sheet found is used first or last so that it does not have to fit into another. Once the first is nailed in place the next one is placed on the *joists*, aligned, and hammered into place using a scrap piece of 2X4 so as not to damage the next sheets edges. After you complete the nailing according to specifications that come with your new shed plans, you are ready to start building walls.

If you are new to laying out or drawing onto wood to show where the different pieces of wood are nailed together have a look below at **illustration # 6**.

ILLUSTRATION # 6

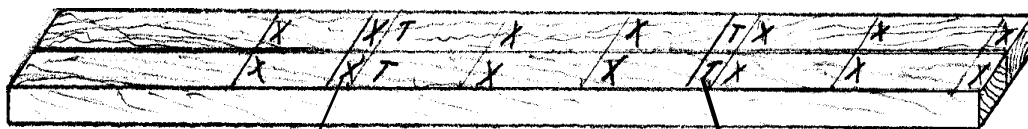

" X " TYPICALLY MARKS THE PLACE WHERE THE STUDS CRIPPLE STUDS, JOISTS AND/OR RAFTERS ARE LOCATED

" T " TYPICALLY MARKS THE PLACE WHERE THE TRIMMER STUDS ARE LOCATED

ILLUSTRATION # 7

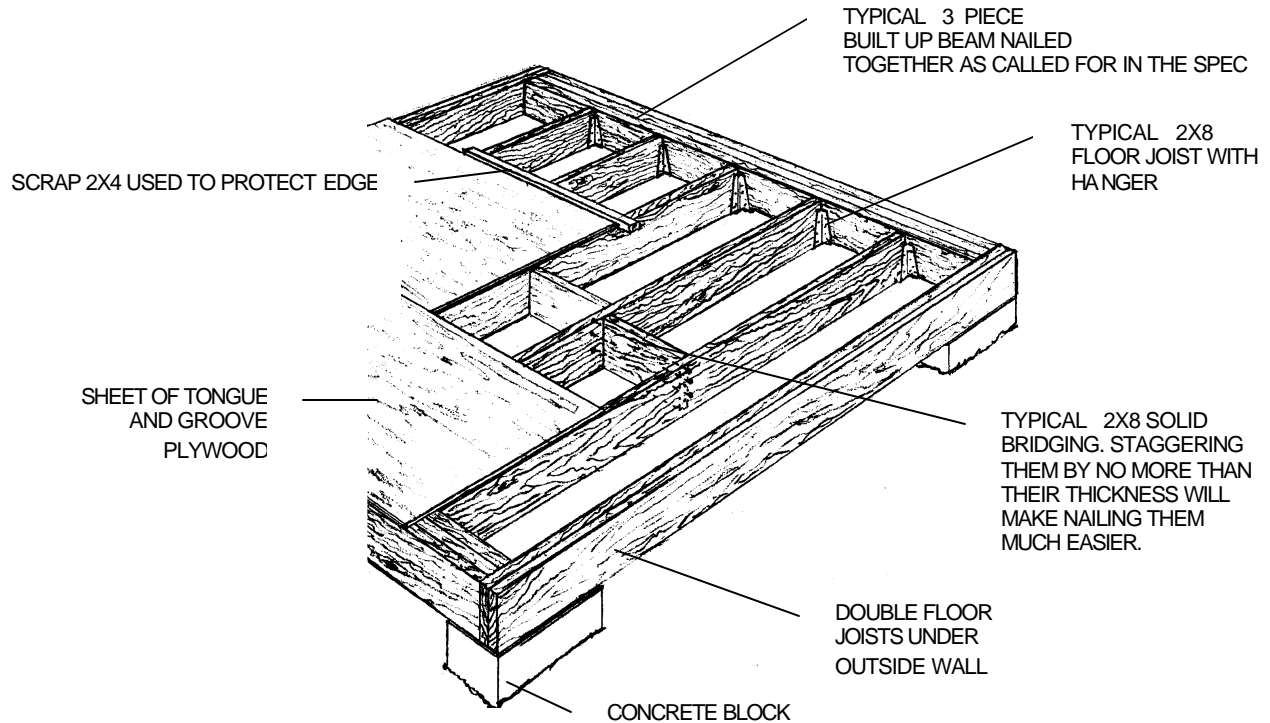

5 WALL FRAMING

5-1 Building Regular Walls

5-2 Building Irregular Shaped Walls

5-3 Building Bigger Walls

5-4 Bracing the Walls

5-1 Building Regular Walls Walls as mentioned are easier to build when laying on a flat surface and then put upright and into place. Look at **illustration # 8** on page 15 so that you are familiar with some of the terms used to describe the different members used in wall construction. Even if you know them by a different name or can't remember them, that's ok because **illustration # 8** will give you a very good idea what building walls is all about. This is the quickest most rewarding part of the project.

ILLUSTRATION # 8

TYPICAL 2PC. 2X4 LINTEL PLACED ON EDGE WITH A 1/2" SPACER TO MAKE IT 3 1/2" WIDE THE SAME WIDTH OF A STANDARD STUD WALL. SEE YOUR PLANS FOR THE ACTUAL LINTEL REQUIREMENTS FOR EACH DIFFERENT OPENING ON EACH OF THE DIFFERENT PLANS. WHERE THE WALL CARRIES NO WEIGHT USE 1 2X4 INSTALLED FLAT WHEN A LINTEL IS NOT CALLED FOR. UNLESS INDICATED OTHERWISE THE TOPS OF THE WINDOWS ARE AT THE SAME HEIGHT AS THE DOORS.

TYPICAL SECOND 2X4 TOP PLATE OVERLAPPED INTERSECTING WALL TO ADD STRENGTH WHENEVER POSSIBLE

TYPICAL WINDOW OR DOOR R.S.O. 42 1/8" X 49 1/4" (ROUGH STUD OPENING) THE WIDTH IS ALWAYS STATED FIRST

TYPICAL TEMPORARY WALL BRACE

TYPICAL REGULAR 2X4 STUD PLACED 16" O.C. THERE MUST BE A STUD EVERY 16" TO SUPPORT THE SHEETING

TYPICAL 3 STUD CORNER AS SHOWN ON THE FLOOR PLAN OF YOUR PLANS THIS SUPPORTS INTERIOR SHEETING

TYPICAL CRIPPLE STUD

TYPICAL TRIMER STUD SHOWN JUST TO THE RIGHT OF A REGULAR STUD IT IS USED TO SUPPORT THE 2 PIECE LINTEL

NOTE

THE EXTERIOR WALL SHEETING IS NOT SHOWN TO AID IN ILLUSTRATING THE FRAMING MEMBERS. MOST OF THE SHEETING WOULD NORMALLY BE INSTALLED BEFORE THE WALLS ARE PUT UP

NOTE

ALL WALLS MUST BE FIRMLY BRACED. SHOWN HERE ARE 2 WAYS THAT YOU CAN DO THIS. A 3RD WAY WOULD BE TO SECURE IT TO ANOTHER INSTALLED WALL. OUTSIDE WALLS SHOULD HAVE A BRACE EVERY EIGHT TO TEN FT. BRACES CAN BE REMOVED WHEN ALL THE FRAMING IS COMPLETED

TEMPORARY WALL BRACE NAILED TO A STAKE DRIVEN FIRMLY INTO THE GROUND

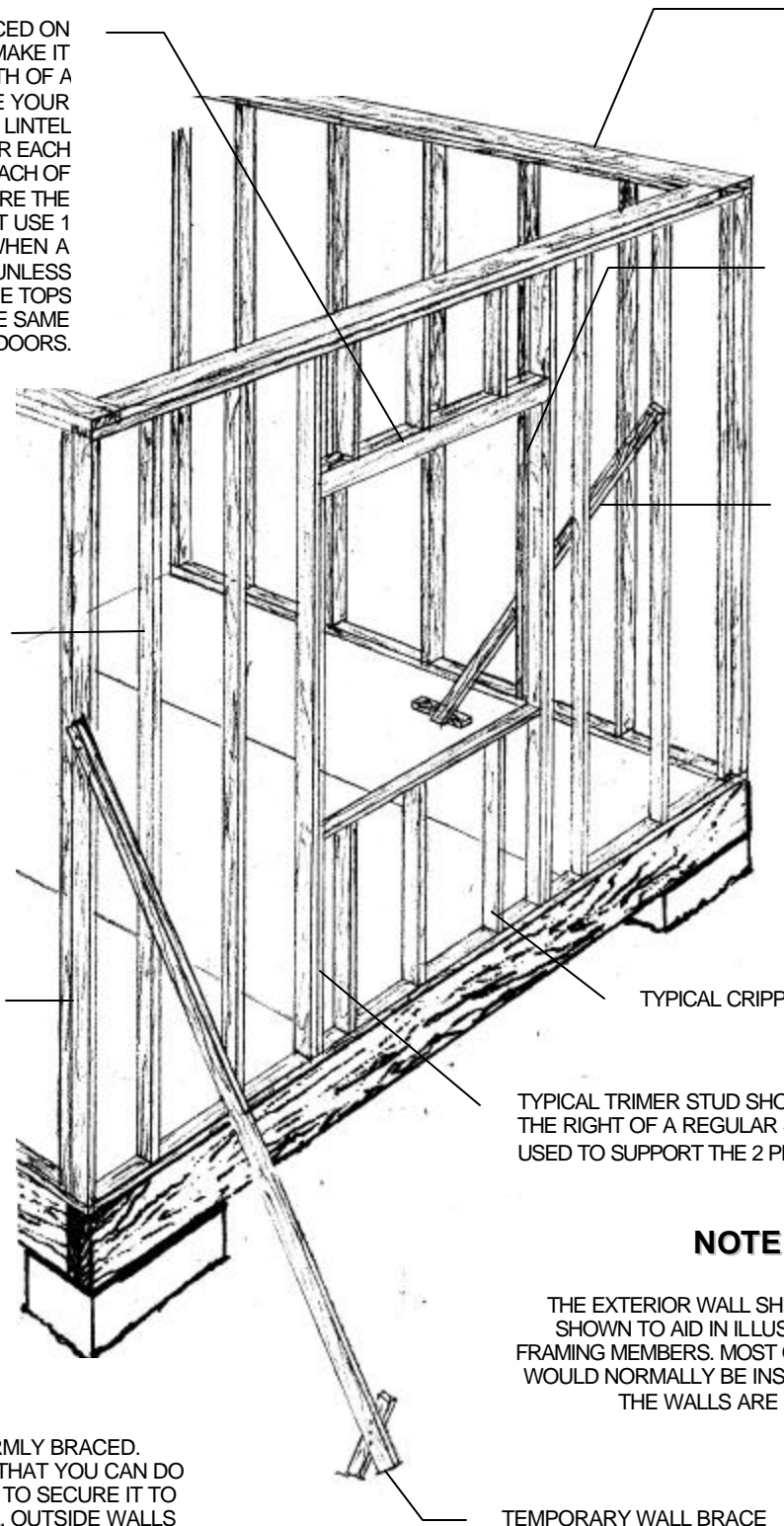

Before you begin building walls review the step-by-step wall building recommendations that came with your plans and your construction site. Consider the help you will have if any and decide where it would be best to start in your particular case where you will put your materials and which wall you want to build last. Remember that the walls when they are built fit or lap together in a certain way, which can be seen in the floor plan.

The very best place to build walls is on your flat wooden floor or *concrete pad* whatever the case may be for your new shed, but because many sheds have smaller floor areas you may have to move some walls aside until they are all built and then installed.

All of the walls in the wall details pages in your new shed plans are given an approximate weight to help you in your building schedule. Larger walls can be built in smaller sections and remember that you do not have to put all the sheathing on and in some cases you will be just lifting the top part of it up into place.

All of our plans have what the construction industry calls a 3 *stud* corner as shown in **illustration # 8** on page 15. This third *stud* gives you *backing* onto which you can nail the inside sheathing to. It should be noted however that the 3 studs are not built in one wall but in two walls as shown in illustration # 8. These corners further indicate how the walls will lap or fit together as shown in illustration # 8 This should illustrate where a little planning is helpful with regards to where it is best for you to start building your walls on your particular construction site.

Walls installed on concrete slabs first have the needed anchor bolt holes drilled into the bottom *sill* plate. The sill is temporarily put in place so that you are sure that they will fit when they are used to secure the wall and then it's installed.

Start the wall construction by choosing 2 straight *sill* plates. One for the bottom and one for the top. Place them on their flat side beside each other and mark them showing where the different *studs* go. The needed *studs*, their location and spacing are typically shown on the "FLOOR PLAN" page that comes with our plans. Again if you are new to laying out or drawing on wood to show where the different pieces of wood are nailed together have a look at **illustration # 6** on page 13. Place the wall *studs* for the corners first. Choose ones that are straightest. Then come the other ones. Remember to always put the crown up. Then place the *trimmer studs*. Nail them to the *sill* plates.

Next install the *lintels*, *sills* and *cripple studs* and nail as per plans and specifications. The actual size of *lintels* will vary greatly with each different plan, which depends on their needs and the roof loads they must carry. In some plans when a *lintel* is not called for just install a *sill* instead of an actual *lintel* because they carry little or no load at all.

Once all the *framing* members are nailed together, make the frame square and install the wall sheathing onto the *framing* members. Your plans will show wall sheathing installed over the 3 piece built up beam and the *header* and double floor *joist*. This gives the sheathing the continuity that makes the siding look better. The sheathing for this area comes from the scrap pieces cut out from the window and door openings. In other words the bottom of the sheet you nail on the wall *framing* does not extend all the way down. This is because it makes the walls too hard to handle and will produce more waste. Nailing the sheets on after the wall is up is also harder to do and this does not make the walls rigid. Rigidity in the walls will help you keep them up straight and square. You should have some sheathing on each wall.

5-2 Building Irregular Shaped Walls Building *gable* ends and irregular walls is not hard. Irregular walls are used in our barn, saltbox style and some other shed plans. They can have from 4 to 7 angles in them but like the *gable* end they are built like wall building is described in sec 5-1 following the steps shown below.

A typical *gable* end along with a chart for “**STEPS FOR GABLE END FRAMING AND LUMBER CUTTING**” is shown in illustration # 9 below. It consists of a bottom plate and 2 angled top plates with *studs* in between.

When it is build in one piece it is installed on top of a wall usually after the ceiling *joists* are in place again this will depend on the help you will have and the size and type of new shed you are building.

Here it is much better to have all the sheeting installed because the *gable* ends are not heavy and you will have to work from a ladder if you install the sheeting after.

Working from ladders should be avoided where possible.

ILLUSTRATION # 9

STEPS FOR GABLE END FRAMING AND LUMBER CUTTING

- 1ST Cut and layout the BP1 for studs at 16" O.C. starting from the center.
- 2ND Cut all studs then nail to the BP1.
- 3RD Cut and layout the 2, TP1 for studs at 16 7/8" O.C. starting from the center at S1.
- 4TH Nail the 2, TP2 to all the studs.
- 5TH Install wall sheeting as advised in the Construction Guide and finish nailing as per specifications.

| DESCRIPTION | CODE | USE | CUT LENGTH | QUAN. | ANGLE | NOTES |
|--------------|------|-----|------------|-------|---------|-------------------------|
| BOTTOM PLATE | BP1 | 2X4 | 84" | 1 | | |
| TOP PLATE | TP1 | 2X4 | 44 1/2" | 2 | 19°/71° | Cut as shown |
| WALL STUD | S1 | 2X4 | 12 1/2" | 1 | 19° | Cut in a point as shown |
| WALL STUD | S2 | 2X4 | 7 1/2" | 2 | 19° | Cut as show n |
| WALL STUD | S3 | 2X4 | 2" | 2 | 19° | Cut as shown |

The lengths mentioned here, when there is an angle cut, are always measured at the longest points.
FOR CLARITY ON ANGLE CUTTING ORIENTATION SEE THE RAFTER CUTTING PAGE.

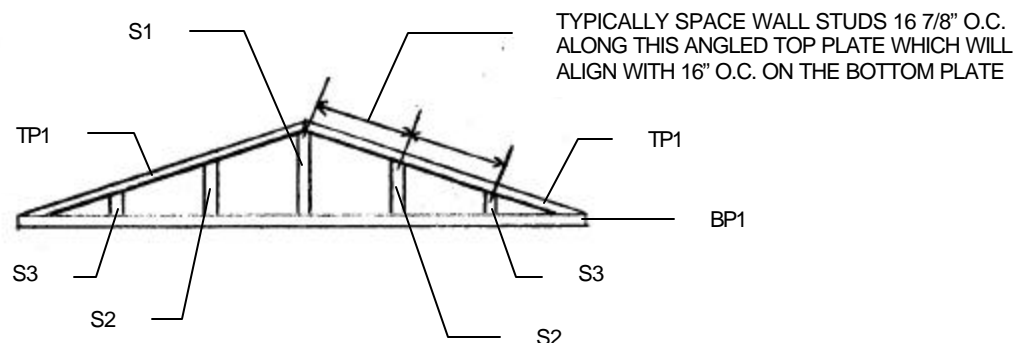

5-3 Building Bigger Walls Walls that are longer than 12' are often built in two. This will depend on the amount of helpers you have. In this case the two parts are then spliced together with the second top plate that is shown in **illustration # 8** on page 15. The second top plate where possible always overlaps the intersecting walls for strength as shown in **illustration # 8**. Where this is not possible such as in our free plans or irregular walls mentioned in sec. 5-2 just use a single top plate. This method can also be used for the back 1/3 of our saltbox style sheds.

5-4 Bracing the Walls Take care when installing the walls so that they are *plumb*, well nailed according to the specifications that come with our plans and are braced as shown in **illustration # 8**. This is important because buildings at this stage of construction are vulnerable to wind.

6 ROOF FRAMING

6-1 Rafter Cutting Templates

6-2 Installing Rafters

6-3 Installing Ridgepoles on Gable Ends

6-4 Barn Style Roofs

6-5 Fascia Boards

6-7 Roof Sheeting

6-1 Rafter Cutting Templates At Just Sheds Inc. we know that roof *framing* can be a difficult part of construction, whether it is a simple roof as shown in our free plans or more complex. This is why we give the needed details in our "RAFTER CUTTING LAYOUT" page in our plans and the 'ACTUAL SIZE RAFTER CUTTING TEMPLATES. They all show the sizes and angles you need to cut. All of them have actually been cut and proven to fit.

The joints in the *rafters* and trusses when nailed together do not have to be of the kind one sees in finished furniture. To have a small gap (1/16"+ -) in one part of the joint here and there is commonly seen in new buildings.

Wood along with the many characteristics described in sec 4-4 is quite pliable and forgiving. A poorly cut birds mouth makes for an open joint as shown on the left side of **illustration # 10**. It will with time and pressure however close as seen on the right side of that illustration.

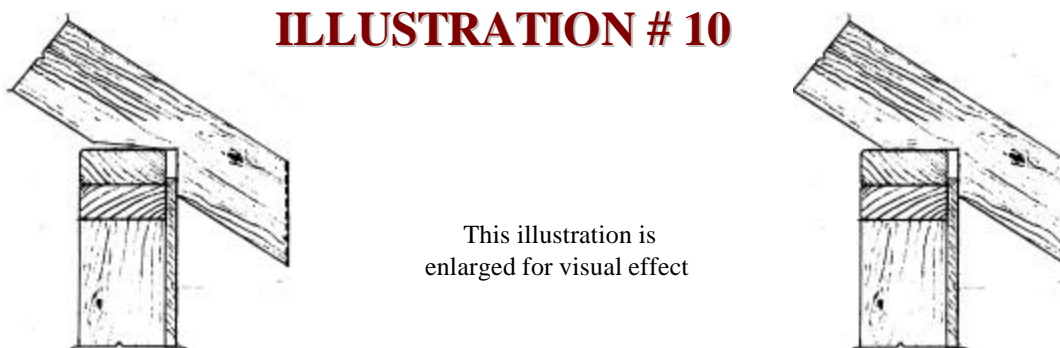

6-2 Installing Rafters Once the walls are in place install the ceiling *joists* when your style of shed allows. Some smaller barn styles and others do not have them. The saltbox style of shed, “1100, 2100 and 3100” series need the rafters in place first because the one end of the ceiling *joist* is nailed to them.

It is helpful when reading this guide to refer to your plans. If you have yet to select or purchase a set, print out the free shed plans so you can refer to it for more clarification on some of the items referred to in the *framing* part of this guide. Looking at the plans for the shed you want to build is also helpful especially as you read about the roof *framing* part in this guide. If your shed plans need the *rafters* first before the ceiling *joists* then cut 2 as shown on your plans and temporarily put them in place with a spacer block (the same thickness as the ridge pole) to confirm they fit. Use them as a template to cut the others and proceed to install them with the *ridgepole* as shown in **illustration # 11**. Once the ridge pole is up you can install the rest of the *rafters* one at a time and alternately first on one side then on the other so as not to push the ridge pole crooked which can happen if you nail them all on one side first. Nail them all according to the specifications that came with your plans. The *ridgepole* can be a little longer and then trimmed to fit. Take care that the *rafters* are installed at right angle to the *ridgepole* or the *roof sheeting* will be difficult to fit.

ILLUSTRATION # 11

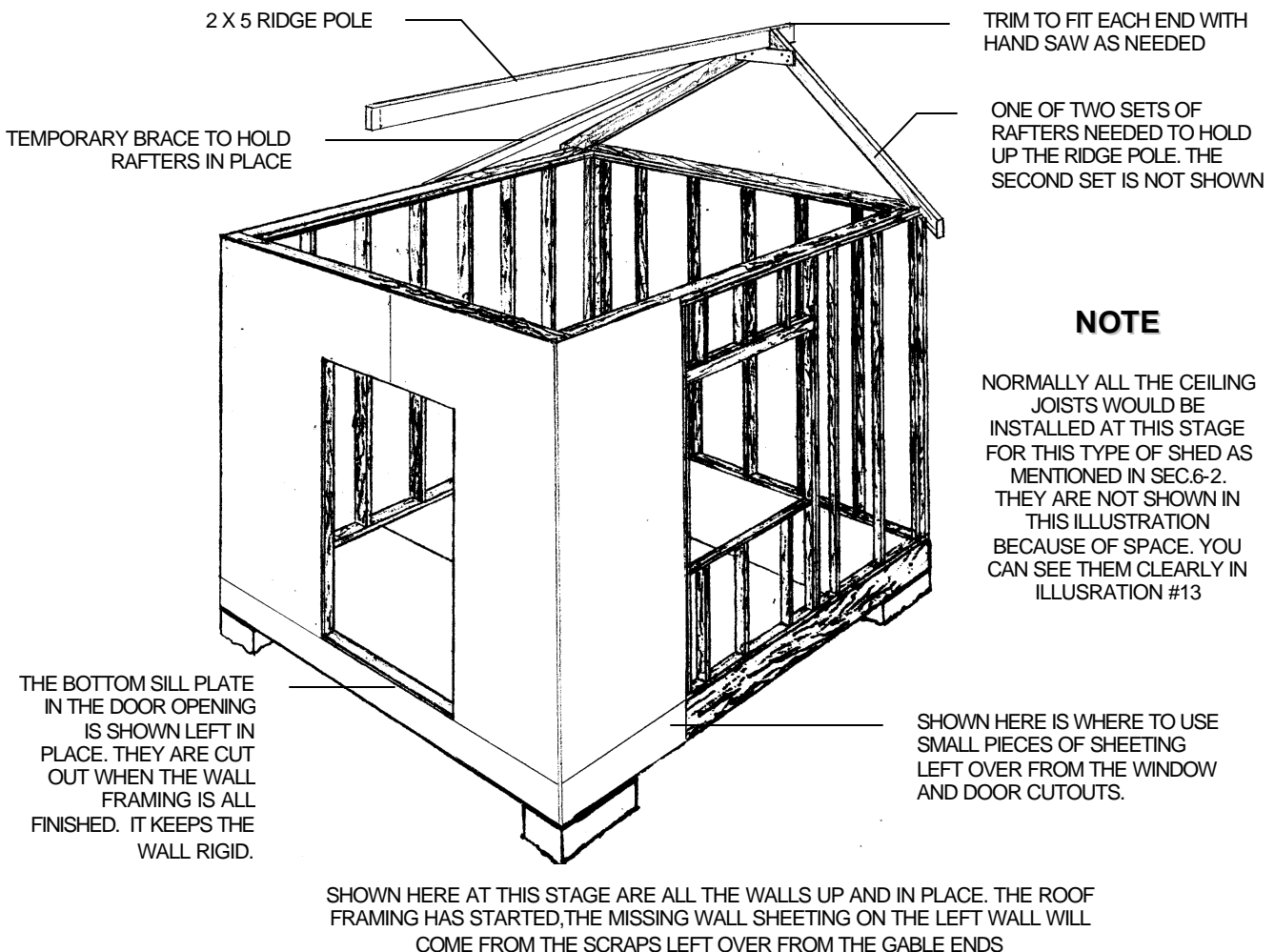

NOTE

NORMALLY ALL THE CEILING JOISTS WOULD BE INSTALLED AT THIS STAGE FOR THIS TYPE OF SHED AS MENTIONED IN SEC.6-2. THEY ARE NOT SHOWN IN THIS ILLUSTRATION BECAUSE OF SPACE. YOU CAN SEE THEM CLEARLY IN ILLUSTRATION #13

6-3 Installing Ridgepoles on Gable Ends When your type of shed plan allows you can install the *ridgepole* on top of the gable ends when they are in place as shown in **illustration # 11** on page 19. You may have to notch the underside of the *ridgepole* as needed where it rests on the *gable* end.

As in sec. 6-2 confirm that the two *rafters* you just cut will fit, then use them as a template to cut the others. Proceed to install them with the *ridgepole* in place as shown in **illustration # 11**. Once the ridge pole is up you can install the rest of the *rafters* one at a time alternately first on one side then on the other so as not to push the ridge pole crooked which can happen if you nail them all on one side first. Nail them all according to the specifications that came with your plans. The *ridgepole* can be a little longer and then trimmed to fit. Always take care that the *rafters* are installed at right angle to the *ridgepole*.

ILLUSTRATION # 12

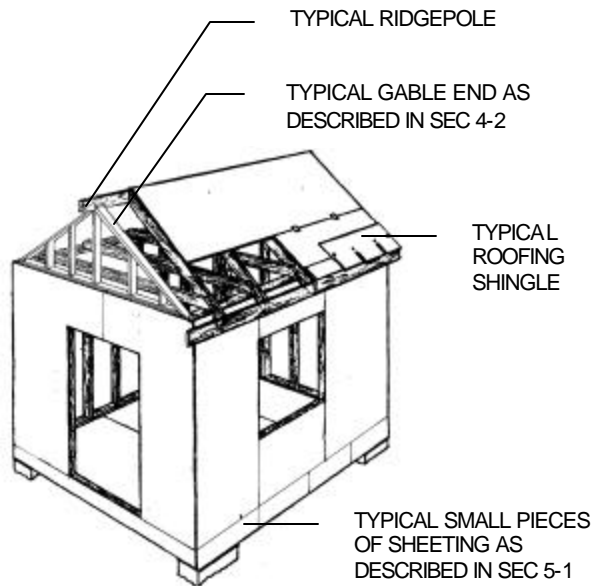
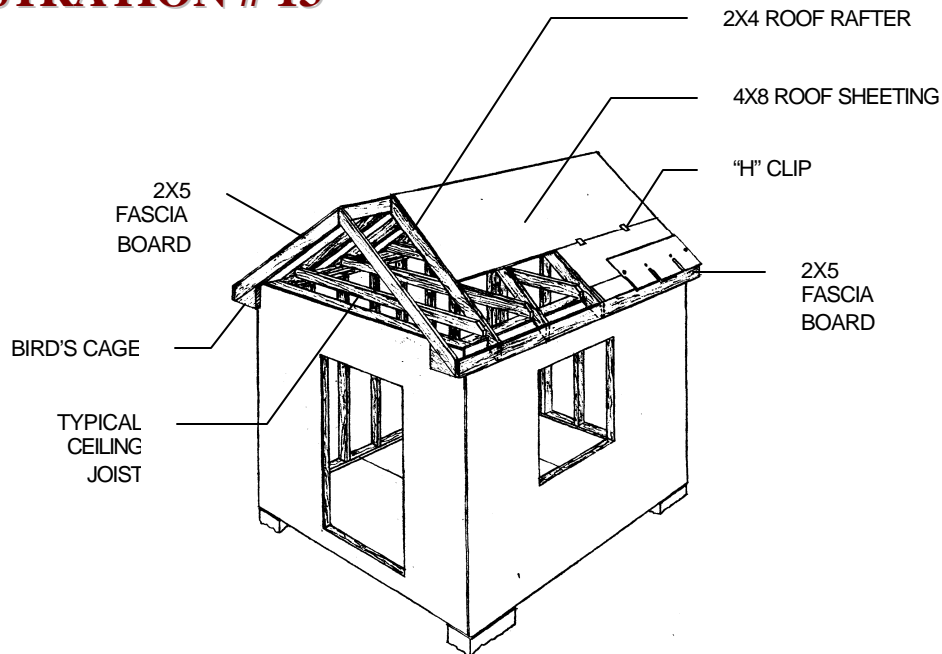

ILLUSTRATION # 13



6-4 Barn Style Roofs All of the barn style shed roofs have a basic curved shape (shown below in a red line) that replicates the very old shape of the Roman arch. Today it is still one of the strongest engineering shapes known to man. All barn roofs should have this shape. To get this curved shape with straight pieces of wood in all of our barn roof shed plans the *rafters* on each side of the roof are laid out so that the lowest *rafter* has a run (a measurement made horizontally) of 1/3 rd of that *span* and a rise of 2/3. The top *rafter* has a run of 2/3 of that *span* and a rise of 1/3.

The gambrel or barn style roofs are framed by building a one-piece roof truss as shown in **illustration # 14**. Just cut the *rafters* and the *gussets* as shown on the plans and nail them together. This is best done on a flat surface such as the floor of your shed. After they are built they are put aside and then installed one by one. Brace them with an angle brace in the same way the *rafters* are braced in **illustration # 11** on page 19. Once the truss type of *rafters* are in place install the 2X4 blocking at the hip and at the peak of the roof as per plans.

ILLUSTRATION # 14

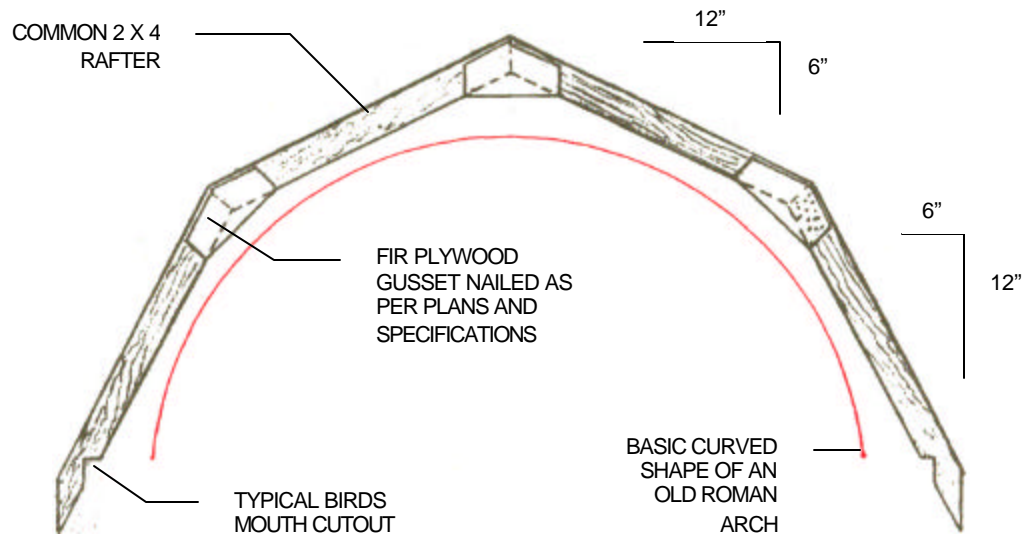

Discovering what we will help you build.

6-5 Fascia Boards When all the *rafters* or trusses are in place install the *fascia* board onto the lower ends of the *rafters* as shown in **illustration # 13**. They can be a little longer and then trimmed to fit after. It is often easier to do it this way. Next install the front and back *fascia* boards at the ends of the *ridgepole* (or install a few short perpendicular lookout *rafters* as shown in **illustration # 15** on page 24 if it does not have a *ridgepole*) and onto the just installed horizontal *fascia* board.

Many of our *fascia* boards call for 2"X 5" lumber. It is at times preferred because it fits the 6" *fascia* better and has the right proportions. A 2"X 6" board may require 8" *fascia*, which can be hard to find in your area.

6-6 Roof Sheeting Next install the *roof sheeting*. It's started at the bottom of the roof *rafters*. Install the "H" clips as called for. They are used to support the sheet's edges just like the tongue and grove *plywood* mentioned in sec. 4-6. The last part is the bird's cage, which is just a block of wood as shown in **illustration # 13** on page 20 having the needed corresponding angles. It is the bird's cage onto which vinyl *soffit* and *fascia* are secured.

7 ROOFING

7-1 Asphalt Shingles

7-2 Cutting Shingles

7-1 Asphalt Shingles Although you can use almost any kind of roofing material on your new shed we recommend asphalt *shingles* in our plans because they are the most popular, durable, inexpensive and are easy to install. Follow all of the manufacturer's instructions that come with your new *shingles*.

Installing the *soffit* and attic venting as called for in our plans is very important as it helps to keep the daytime temperature of the *shingles* down. *Shingles* that are routinely subjected to cool nights and then very hot days have a shorter lifespan. The vents called for in the plans can be on any side of the roof as long as they are near the top of it.

7-2 Cutting Shingles The best way to cut *shingles* is to use a hook blade that fits into a common utility knife. Stanley makes both and they are readily available and inexpensive to buy. Just hook the blade on the edge of the shingle and pull the knife firmly towards you. This cuts much better than the often-recommended shears or tin sips which is like cutting sand paper with a pair of good scissors

8 WINDOW AND DOORS

8-1 Installation

8-2 Using Other Products

8-3 Garage doors

8-1 Installation Installing the windows and steel doors in our shed designs is easy because there are no difficult components to make or buy. The units recommended in our materials list are chosen with decades of experience. They are chosen for their cost effectiveness, appearance, availability, quality and ease of installation. Which is also a long established construction industry wide way of building.

This is important, as they will give years of good service and satisfaction. Satisfaction that lasts longer than the monetary thrill of buying something cheap or for some making doors that will sag and not close or lock properly. The good-looking appearance and strength of steel doors also helps protect your property by helping to prevent break-ins.

These windows and doors come assembled in their frames. They fit right into the rough stud opening that are called for in our plans, which are specified by the manufacturer. For more information on this visit some of their web sites.

8-2 Using Other Products You can of course, use any make of windows and doors that you like but we strongly recommend that they are similar in appearance and function and always check any *rough stud opening* before buying or building. The window and doors can be moved or deleted within the same walls in our plans without affecting the structure.

8-3 Garage doors One piece or sectional roll up garage doors can be used instead of the double or single doors called for in our plans provided the shed is built with a concrete floor because garage doors are set in a bit and they do not have a *sill*, which will then expose a wooden floor to rain, which will cause rotting.

Garage doors because of their size and lower cost are not sold or distributed widely by one manufacturing company like other windows and doors. They are more of a local product and so you should contact a supplier in your area regarding their product sizes and rough *stud* openings.

You should use a 2 piece *lintel* made up of 2"X 8" for door openings that *span* 7 to 8 1/2 feet in width. The rest of the *framing* is the same as described in sec. 5.

9 SIDING

9-1 Installation

9-2 Asphalt Paper

9-1 Installation Installing the siding is another fun part of your shed building project. We recommend vinyl as the best material to cover your shed because it is maintenance free, comes in a host of colors and patterns that you can choose from and it's inexpensive to buy.

Vinyl siding is also a proven product. It's easy to install and keeps its good looks for a long time. Although you should follow the instructions that come with the siding, **illustration # 15** on page 24 shows some of the items common to all such siding. Horizontal rather than vertical siding was chosen for this illustration.

You can also use almost any other siding including 4X8 sheets.

9-2 Asphalt Paper First install vertically a full width piece (36") of # 15 *asphalt paper* on each of the corners. Just use a few of the roofing nails here and there to hold the paper in place. Later on the siding and trim when finished will hold it in place. The same roofing nails are used for the siding and trim. Next install the outside (and inside corners if your new shed has them) over the vertical piece of *asphalt paper*. Next install a strip of # 15 *asphalt paper* horizontally under the window as shown in **illustration # 15** on page 24.

Care must be taken to give the paper a big overlap so that the wind will not drive rainwater in behind it. Horizontal laps should be 4" and vertical laps should be about 15" For better results vertical laps can be sealed with tar or another sealant that you may already have.

Next install the starter strip onto the bottom of the wall into which the first piece of siding slides up, and locks into. The siding is then nailed and then comes the next piece, etc. Install all trim and moldings over the building paper, except for *soffit fascia*. Trim must be installed around the windows and doors before you get to it with the siding. Install the "F" molding on the siding to receive the *soffit* material. Next comes the *soffit* which slides into the "F" molding. Then install the under *sill* trim just under the roof *shingles* and slide the *fascia* up into it.

ILLUSTRATION # 15

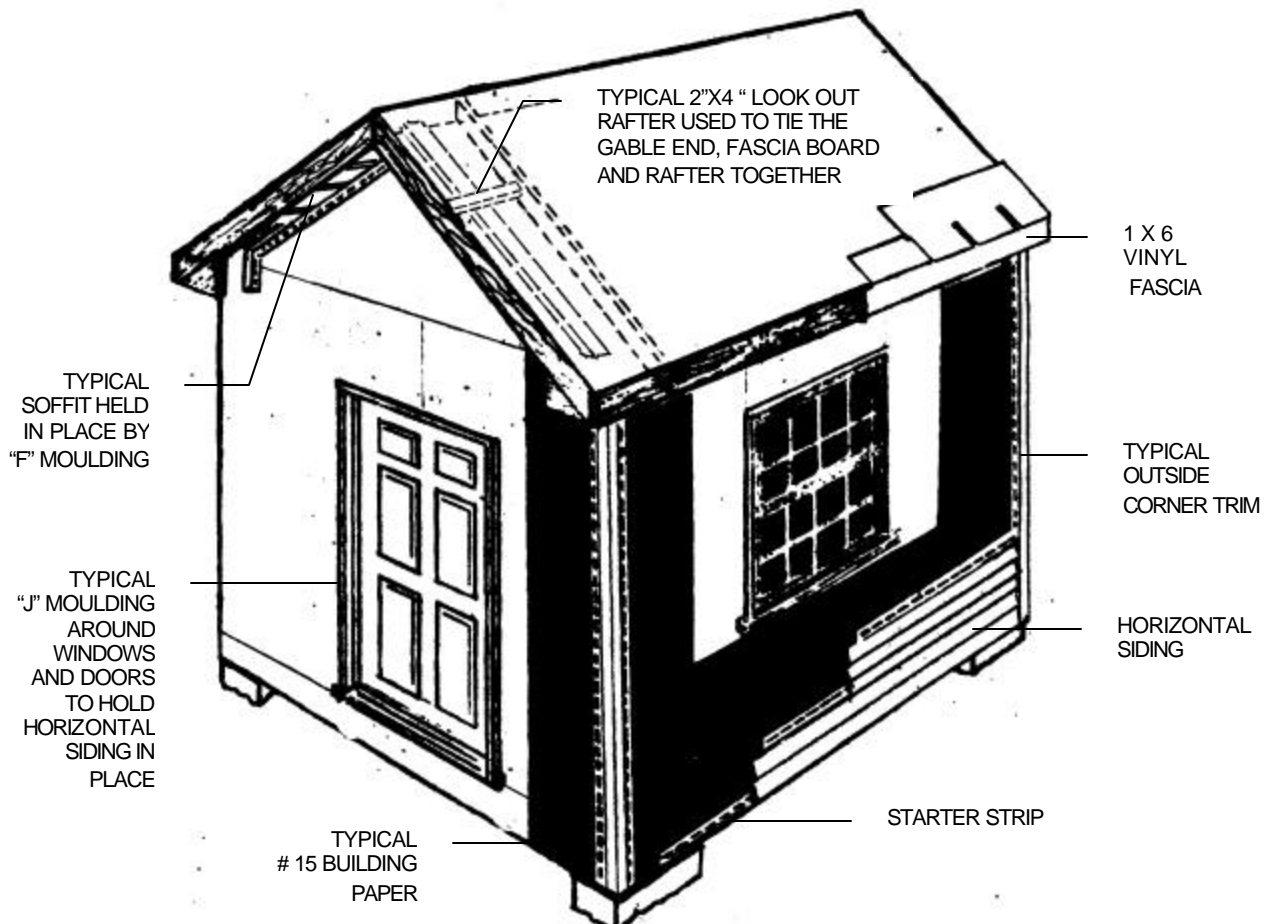

10 GLOSSARY OF TERMS USED

Our abridged glossary of terms should be used with this guide and all our plans.

Anchor bolts- Long steel bolts used to secure wooden *Framing* or a wooden 2X4 *Sill Plate* to a *Concrete Pad* or concrete *Slab on Grade*. Usually “L” or otherwise shaped to hold in the concrete as shown in illustration G-1. *Saddle Anchor* is somewhat similar to steel *Anchor bolts* but used to secure a wooden beam or post to concrete blocks or a *Concrete Pad* or *Slab on Grade* as shown in illustration G-2.

ILLUSTRATION G-1

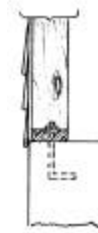
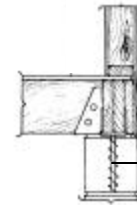

ILLUSTRATION G-2



Saddle anchor

Aspenite- A popular brand of manufactured 4X8 sheet of wood paneling made out of small wood chips and glue. Often used instead of *Plywood* in the walls and roof sheathing. Its cost is about 60% of *Plywood*. Also called Oriented Strand Board or wafer board.

Asphalt paper- Term for papers, felts, and similar sheet materials used in buildings. Also called tar paper or building paper. It comes in long rolls.

Backing- *Framing lumber* installed between the flooring *joists*, *Ceiling joists* and wall *Studs* to give additional support for interior and *Plywood* flooring sheets near their edges. Their use is shown in illustration G-3. As it can be used in the second floor of plans where the floor *joists* and roof *Rafters* meet. Also use for interior trim related items, such as handrail and shelving brackets and cabinets.

ILLUSTRATION G-3

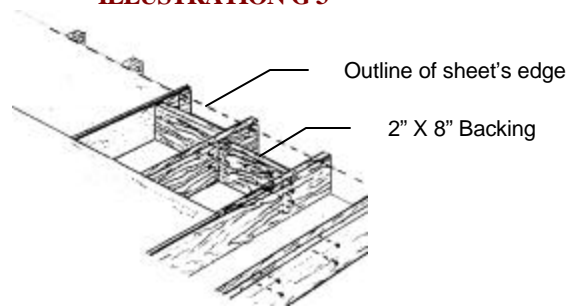

Outline of sheet's edge

2" X 8" Backing

Bird's Mouth- Notch cut out of a roof rafter so that it fits squarely on top of a wall as shown in illustration G-4.

ILLUSTRATION G-4

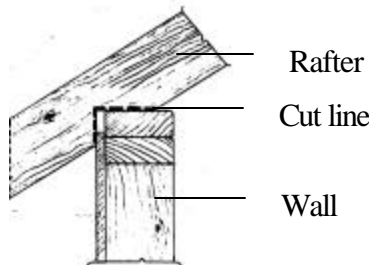

Rafter

Cut line

Wall

ILLUSTRATION G-5

Bird's Gage- Framing on the bottom of a fascia board so that it has a squared or look ready for finishing materials as shown in illustration G-5.

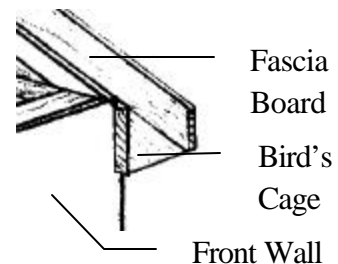

Fascia Board

Bird's Cage

Bird's Cage

Front Wall

Bridging- Wood members that are nailed in a diagonal position between the floor *joists* at mid-*span* for the purpose of bracing and to prevent *joists* from twisting. They spread the load to the adjacent floor *joists* making the wooden floors in our shed plans much stronger without using a lot more material.

Ceiling joist- Parallel *Framing* members used to support ceiling loads and supported in turn by beams and sidewalls. Also called roof *joists* when they act as *Rafters* and *joists*.

Chalk line- A line of chalk made by snapping a string that is dusted with chalk. Used for making very straight lines for aligning different parts of our sheds.

Concrete Pad- Type of foundation with a concrete floor, which is placed directly on the soil or gravel bed. The edge of the slab is usually thicker and acts as the footing for the walls.

It is a pour in place concrete floor on which small buildings like our sheds are built. Also called a *Slab on Grade*.

Cripple Stud- Short vertical piece of 2X4 *Framing lumber* installed under or above a window or door rough *Stud* opening.

Fascia- Boards attached to *Rafter* ends at the eaves and along *Gables*. Can also mean the maintenance free (no painting required) finished vinyl trim that is called for on all our shed plans.

Framing- The practice of constructing the skeleton of a building that is usually made from wooden members and then covered with boards or sheathing.

Framing lumber- Lumber that is commonly used to build the structural parts of a building. It is available in many popular sizes such as 2X2, 2X3, 2X4, 2X5, 2X6, 2X8, 2X10 and 2X12. Depending on their size they come in many lengths that range from 6 to 16 feet and longer. The size they go by i.e. 2"X4" can be somewhat confusing because in the past they were cut to this actual size. Today they are still cut to that same 2X4 inches but that 2X4 becomes 1 ½ X 3 ½ because they are now planed (made smooth) and kiln dried to about 19% moisture content, which makes all of these popular sizes smaller. They have however maintained their old names, which does cause some confusion.

Frost line- The maximum depth of frost penetration in soil at which the earth will freeze. This depth varies in different parts of the world. Building departments will know where the *frost line*, if any, is in your area.

Gable- The upper end of an outside wall. Mostly triangular shaped, it is the area that is beneath the roof.

Grade- Ground *Level* or the elevation at any given point. Also the quality of a piece of *Framing lumber*.

Gusset- *Plywood* used to provide a connection at the intersection of wood members. Most commonly used at joints of *Rafters* and wood trusses.

H Clips- Small metal clips formed like the letter "H". They fit at the joints of two *Plywood* sheets to stiffen the edges and the joints. Works something like *Backing*.

Header- Beams or joists installed perpendicular to the main *joists* and to which *joists* are nailed. For a stairway or other opening. Also a wood *Lintel* or a horizontal structural member over an opening for a door or window.

J Channel- Metal or vinyl trim installed against a window or door's brick molding into which siding fits.**Joist**- Wooden 2 X 8's, 10's, or 12's that run parallel to one another. They are the structural part structural part

Joist- Wooden 2 X 8's, 10's, or 12's that run parallel to one another. They are the structural part of a floor or ceiling supported in turn by beams or walls. Also see *Framing lumber*.

Joist hanger- A "U" shaped metal bracket used to support the end of a floor joist and usually attached to a beam or *header* with nails. They can also be used as a *Ceiling joist* hanger. of a floor or ceiling supported in turn by beams or walls. Also see *Framing lumber*.

ILLUSTRATION G-6



Level- Actually a true horizontal, perfectly flat. Also a carpenter's tool used when building to determine *Level* (horizontal) or plumb (straight up and down).

Lintel- A horizontal structural *Framing* member that supports the load over a window or door opening.

Live load rating- The designed weight carrying capacity of a shed floor. Excludes the weight of the material it was built with.

O C- On Center- The measurement of spacing for *Studs*, *Rafters*, and *joists* in a wood frame building. It is the distance from the center of one member to the center of the next hence the name "*On Center*". In practice however it is actually the very same as the distance between left side of one *Stud* for example to the left side of the next *Stud* and onto the next *Stud* etc. This practice of course works the same for the right side of the *Studs*. It is commonly used to layout *Studs Rafters* etc.

Penny- An old name but still applied to nails. It originally indicated the price per hundred. The term has become a way to measure nail length and is abbreviated by the letter "d". Normally, 16d (16 "penny") nails are used for *Framing*. For clarity Just Sheds Inc. only describes the size of nails by their actual length.

Pier- A column of masonry or poured concrete usually used to support other structural members.

Pitch- The slope of a roof or the ratio of the rise to the run. Roof slope is expressed in the inches of rise, per foot of horizontal run. The roof shown in illustration G-7 has a 4/12 *pitch*. This important information allows experienced carpenters to layout *Rafters* etc. This information is important unless plans come with an actual size *Rafter cutting template*.

ILLUSTRATION G-7

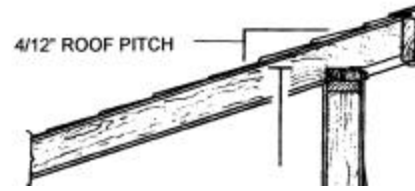

Plate- A 2 X 4 that lies horizontally within a framed structure, such as: *Sill Plate* or a *Sole Plate*.

Plumb- Exactly vertical and perpendicular, perfectly straight up and down.

Plywood- Usually a 4X8 foot sheet of wood made of many layers of veneer glued together.

Precut Studs - Wall *Studs* that are already cut square at the ends and to the exact length usually 92 1/2 This length along with one bottom and two top *Sill Plates* will equal and make a wall that is 97" high. This one inch more than eight feet allows for an eight-foot ceiling when flooring and sheathing on the ceiling are installed. Most of our plans where applicable call for these very handy *precut studs*.

Rafter cutting template- Sheet or sheets of copy righted material created by Just Sheds Inc. that are provided to our customers exclusively with all our plans. This gives them the actual size traceable angles needed to cut all of the angles. This makes our roofs fun and easy to build.

ILLUSTRATION G-8

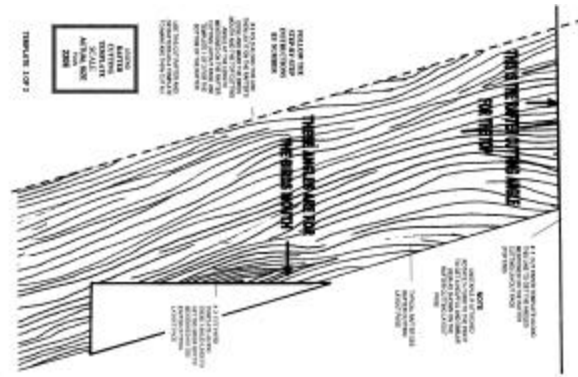

The template shown here for plan # 1220 in illustration G-8 is at a smaller *scale* than comes with all of our plans.

Rafter- Lumber used to support *roof sheathing* and roof loads. In shed plans they are mostly 2X4 or 2X6 The *Rafters* that are used in a flat roof are sometimes called roof *joists*.

Re-bar- Reinforcing ribbed steel bars installed in *Concrete Pads* or foundations. It is designed to strengthen concrete. Comes in many thickness and lengths.

Ridgepole- A board placed at the top ridge of the roof onto which the top ends of other *rafters* are nailed.

Roof sheathing- The *Plywood* panels or sheet material nailed to the roof *rafters* on which *Shingles* are laid.

Rough Stud opening R.S.O. The horizontal and vertical framed measurement of a window or door opening into which a completely built or bought window or door will fit. The width or distance from left to right is always the first measurement given and the top to bottom or height is always the last measurement given.

The *R.S.O.* shown in illustration G-7 is uniformly stated in the "Construction Industry" as 44" X 36"

ILLUSTRATION G-9

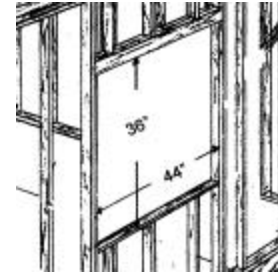

Saddle Anchor- See *Anchor bolts*.

Scale- Dimensions used to express relative proportions of drawings. The *scales* used by Just Sheds Inc in our plans range from 1/4" = 1'-0", to actual full size drawings. Effectively 1/4" scale drawn on our plans equals 1 foot in the actual building.

Shed roof- A roof containing only one sloping plane.

Shingles-Roof covering that can be made of asphalt, asbestos, wood, tile, slate, or other material cut to many different shapes and sizes.

Shutter- Decorative frames in the form of doors located on the sides of a window. Shutters look best when made as though when closed they cover the window for protection.

Sill- The single 2X4 *Framing* member that lays flat against and bolted to the *Concrete Pad* or slab with *Anchor bolts*. Can also be the lower member of an opening, like a door or window *Sill* or the bottom sole *plate* in a wood framed wall.

Slab on Grade- See *Concrete Pad*.

Snow load rating- The designed snow weight carrying capacity of roof rafters or roof joists. Excludes the weight of the material it was built with.

Soffit- Part of a building area below the eaves and roof overhangs. The underside of the roof outside that overhangs the walls.

Span- The clear and total distance that a *Framing* member carries a load without support between structural supports like beams or walls.

Step flashing- Metal flashing used where a sloping roof meets vertical wall surface. About 6"X6" bent at a 90 degree angle, and installed behind siding and over the top of the lower layer of *Shingles*. Each piece overlaps the one beneath it the entire length of the sloping roofline. They are not visible when properly installed.

Stud- A vertical wood *Framing* member nailed to the horizontal *Sill Plates* also see *Cripple Stud*.

ILLUSTRATION G-10

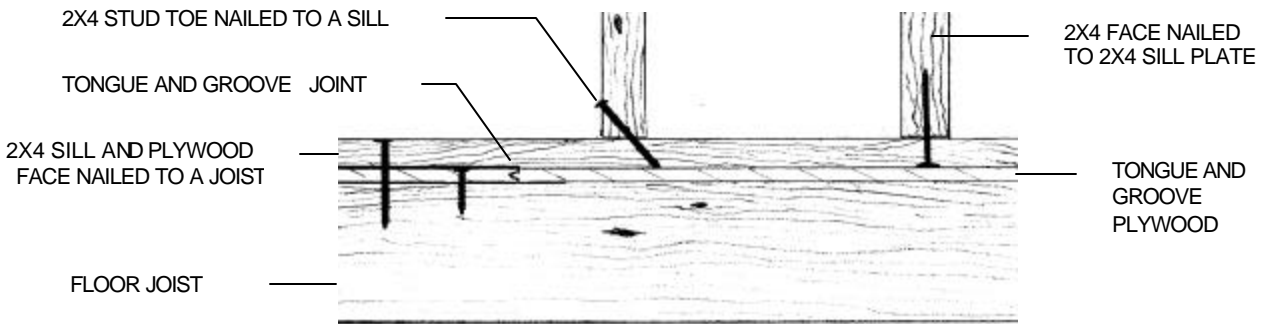

Tongue and Groove- A joint made by a tongue that fits into a corresponding groove in the edge of another board or sheet of *Plywood*. It makes a tight flush joint in the boards or sheets that has the structural effect of them becoming one as shown in illustration G-8

Toe nailing- To drive a nail in at a slant, as shown in illustration G-8. The *stud* shown to the right, is face nailed to the *sill plate*. The *plywood* and the *Sill Plate* are face nailed into the floor *joist*.

Treated lumber- Wood that has been impregnated under pressure with chemical pesticides such as CCA (Chromated Copper Arsenate) to reduce damage from rot or insects.

Often used for wood that is outside.

Copyright © 2005 Just Sheds Inc. All rights reserved

Trimmer Stud- The vertical *Stud* that is shorter than the main *Studs* and it supports a *Lintel* over a door or window opening.

Wire mesh- Reinforcing steel that is like cow fencing in appearance but thicker. Sold in big rolls or 4X8 sheets. Used in some of our *Concrete Pads* or foundations to strengthen the concrete.

11 CONCLUSION

This guide is intended to help the do-it-yourself shed builder when using our plans. It tries to avoid lengthy descriptions and methods not commonly used in shed construction, which would make the guide too long.

On the other hand it should be noted that building sheds involves carpentry more than anything else and this trade alone can involve four years of training and apprenticeship, which illustrates how much there is to know.

It should also be recognized that some of our sheds are big building and they all differ from other building projects such as building a picnic table

Therefore it should be remembered that there are better and other sources of in depth information on the different subjects covered here including books from the library and manufacturer's web

